

P3 Science Weighted Assessment 2 Past Paper
Rosyth School

KHC ONLINE EDUCATION

Online Tuition - IGCSE / GCSE / IB / SG MOE / CBSE/US/UK



Rosyth School
Weighted Assessment Two 2020
SCIENCE
Primary 3

Name: _____

Marks:

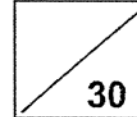

Class: Pr _____

Register No. _____

Duration: 45 min

Date: 27 August 2020

Parent's Signature: _____

Instructions to Pupils:

1. Do not open the booklet until you are told to do so.
2. Follow all instructions carefully.
3. For questions 1 to 8, shade the ovals on the Optical Answer Sheet (OAS).
4. For questions 9 to 13, write your answers in the spaces provided.

	Maximum	Marks Obtained
Q1-Q8	16 marks	
Q9-Q13	14 marks	
Total	30 marks	

For each question from 1 to 8, four options are given. One of them is the correct answer. Make your choice (1, 2, 3 or 4) and shade the correct answer on the Optical Answer Sheet (OAS). [16 marks]

1. The diagram below shows organism J growing on a tree trunk.

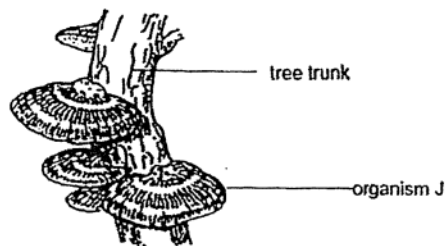

Which of the following statements about organism J is correct?

- (1) It reproduces by seeds.
 - (2) It can make its own food.
 - (3) It feeds on other living things.
 - (4) It does not need water to survive.
2. The diagram below shows an umbrella made of material X.

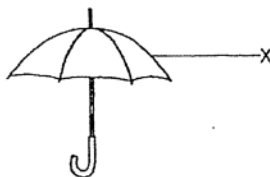

Which one of the following properties of material X is the most important in making an umbrella to be used on rainy days?

- (1) Strength
- (2) Flexibility
- (3) Waterproof
- (4) Transparency

3. The flow chart below shows the classification of some animals.

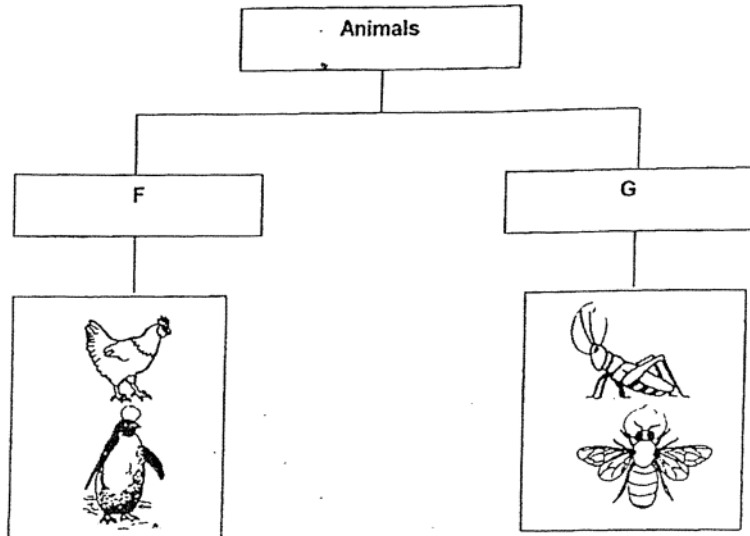

Which of the following headings correctly represents F and G?

	F	G
(1)	Have wings	Do not have wings
(2)	Lay eggs	Give birth to young alive
(3)	Has three body parts	Does not have three body parts
(4)	Does not have a pair of feelers	Has a pair of feelers

4. Which of the following is the function of muscular system in the human body?

- (1) It supports the body and gives it shape.
- (2) It allows different parts of the body to move.
- (3) It breaks down food into simpler substances.
- (4) It transports blood and oxygen to different parts of the body.

5. Study the flow chart below carefully.

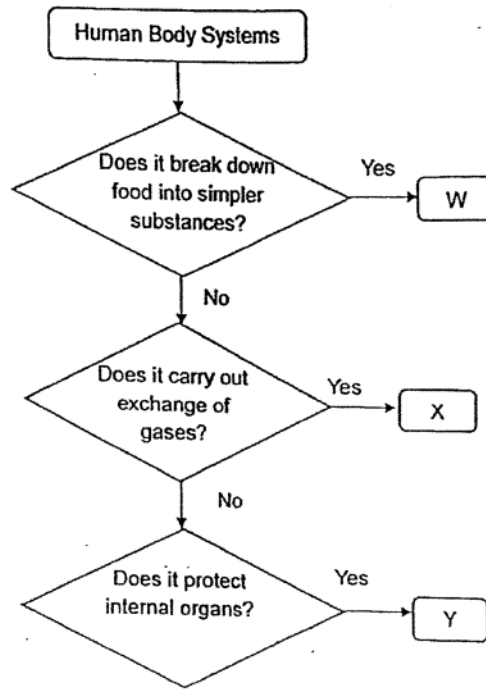

Which of the following represents the human body systems correctly?

	W	X	Y
(1)	Digestive	Respiratory	Muscular
(2)	Muscular	Skeletal	Digestive
(3)	Digestive	Respiratory	Skeletal
(4)	Digestive	Muscular	Skeletal

6. The diagram below shows the arrangements of four magnets. The north poles of the magnets have been marked by the letter N.

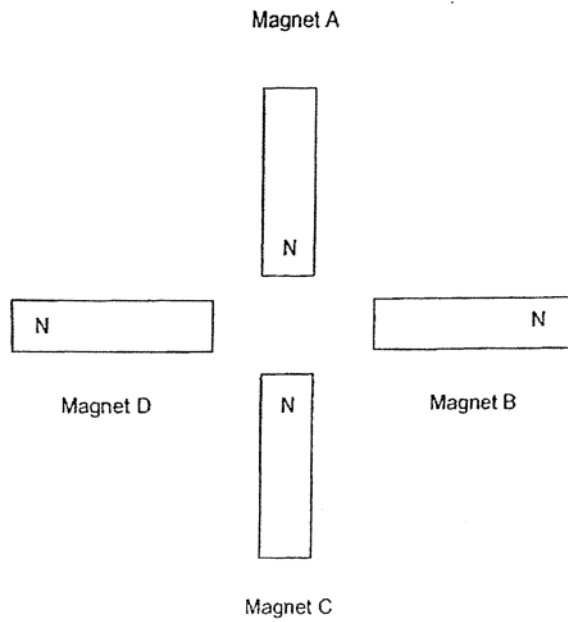

Which of the following statements about the magnets is correct when they move towards each other?

- (1) Magnet B and Magnet C will repel one another.
- (2) Magnet D and Magnet B will attract one another.
- (3) Magnet A and Magnet C will attract one another.
- (4) Magnet B and Magnet C will attract one another.

7. The diagram below shows a magnetic separator machine. It separates magnetic materials from non-magnetic materials as they move on the belt. There is a magnet in the machine as shown below.

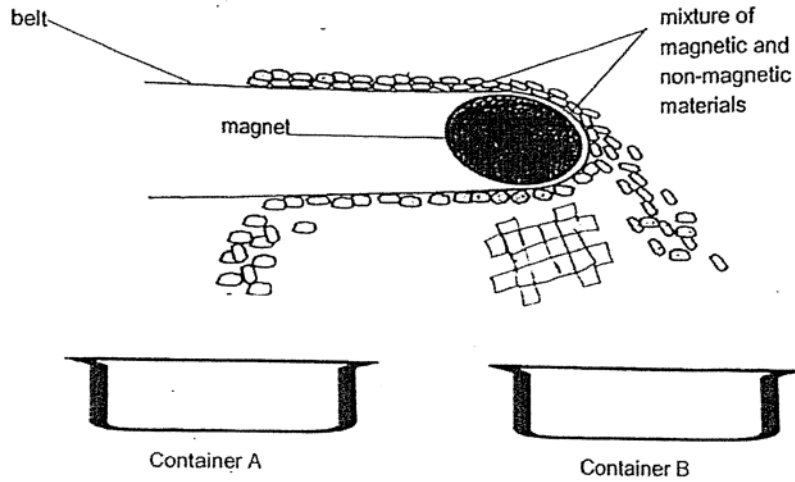

Which of the following materials will be collected in Container A and Container B respectively?

	Container A	Container B
(1)	rubber and plastic	steel and iron
(2)	iron and steel	rubber and plastic
(3)	iron and aluminium	rubber and plastic
(4)	steel	rubber and iron

8. Study the diagram below.

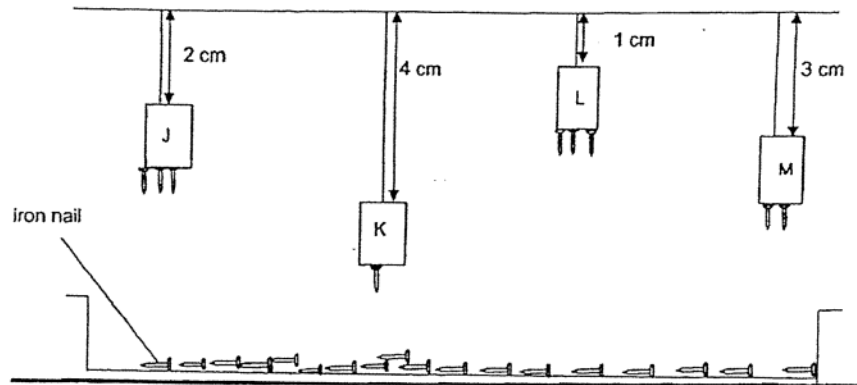

Based on the diagram, arrange the magnets according to their magnetic strength from the weakest to the strongest.

- (1) K, M, J, L
- (2) M, K, J, L
- (3) K, J, M, L
- (4) K, M, L, J

For questions 9 to 13, write your answers in the blanks provided. [14 marks]

9. Study the pictures below.

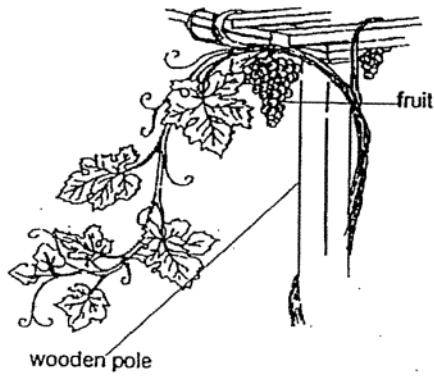

Plant G

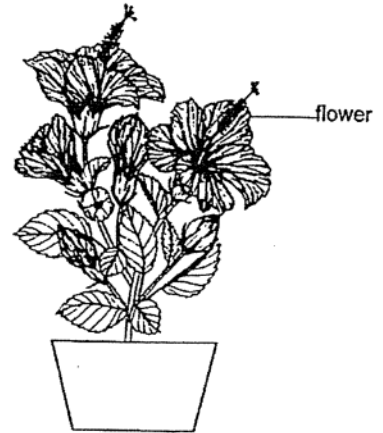

Plant H

(a) In what way is the stem of Plant G different from the stem of Plant H? [1]

(b) Plant H has flowers. Do you think Plant G bears flowers too? Explain why. [1]

10. The diagram below shows one of the human body systems.

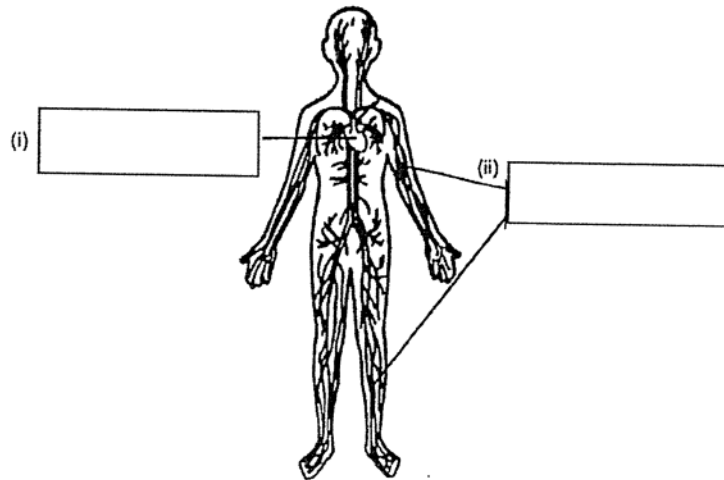

(a) Name the two parts (i) and (ii) in the boxes above. [2]

(b) Which one of the human body systems is shown above? [1]

(c) Describe the function of the human system shown above. [1]

11. The diagram below shows four discs P, Q, R and S on a plastic rod. Some of the discs are magnets while others are not.

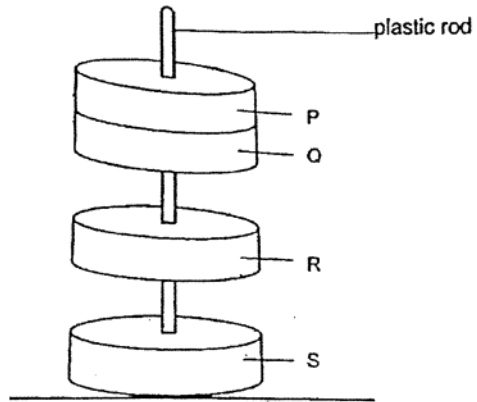

Read the statements below carefully. For each statement determine whether it is 'True', 'False' or 'Not possible to tell'. Put a tick (✓) in the correct box. [2]

Statement	True	False	Not possible to tell
(a) P is attracted by Q.			
(b) Q is a magnet.			
(c) R is repelling Q.			
(d) S is not a magnet.			

12. In the experiment below, John attached a bar magnet to a retort stand. He tied a paper clip to a wooden block using a piece of string. He observed that the paper clip was pulled up by the bar magnet as shown in the set-up.

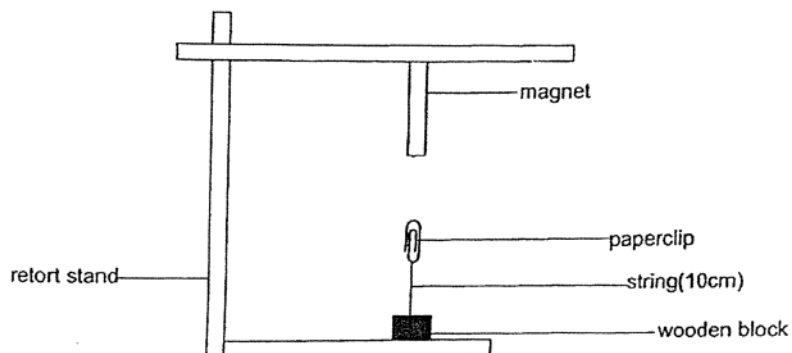

- (a) Which one of the following statements is correct? Put a tick (✓) in the box for your answer. [1]

The above set-up shows that:

Magnet can attract from a distance.

Magnet can attract magnetic object only.

- (b) Should John use a stronger or a weaker bar magnet if the string for the set-up above is 5cm long? Explain why. [2]

13. The diagram below shows a steel toy car being picked by the iron nail.

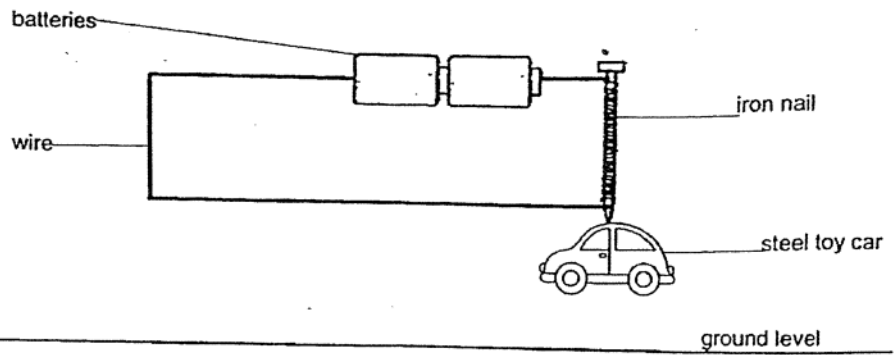

It took some time for the iron nail to pick up the toy car.

(a) State one way the steel toy car can be picked up faster without moving it nearer to the magnet. [1]

(b) After five hours, the batteries ran out of power. What would you observe? Explain why. [2]

Observation: _____

Explanation: _____
